

FITTING INSTRUCTIONS FOR COLD AIR INDUCTION UNIT

FORD AU XR6 & XR8

Part # CAI009

Kit Includes:

1x Induction Unit
1x Intake Tube
4x Self-Tapping Screws
1x 10mm Bolt & Washer
2x Foam Strips
1x Aluminium Air Scoop

Tools Required:

Phillips Screwdriver
Hacksaw Blade
10mm Socket

1. Remove the original induction unit by undoing the 2x self-tapping screws. Discard.
2. Undo the clips for the top of the airbox. Move top aside.
3. Remove the bottom of the airbox by undoing the 3x 10mm bolts.
4. Using the intake tube supplied as a guide, mark and cut the bottom of the airbox to enlarge the existing hole. Attach the narrower foam strip to airbox to ensure a good seal. Attach the wider foam strip to the inner edge of the intake to ensure a good seal when the induction unit is inserted. Fit the intake tube supplied to the bottom of the airbox and secure with 2 of the screws supplied.
5. Refit the bottom of the airbox with the original 3x 10mm bolts.
6. Insert the induction unit supplied into the intake tube and line the front of the unit to the existing holes. Secure with the remaining 2 screws supplied.
7. Reattach the top of the airbox.

To attach the air scoop:

1. Remove the plastic clip directly in front of the mouth of the induction unit.
2. Attach scoop by sliding one end under the grill and replace the original plastic clip to secure.
3. Secure the other end with the 10mm bolt & washer supplied.

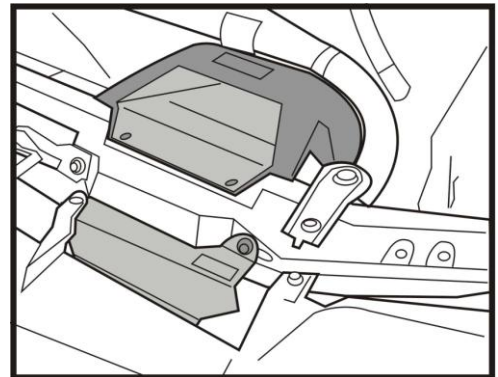

NB: For a good vacuum seal you may wish to apply silastic to the edge of the intake tube that connects to the airbox.

Please note that the engine computer may take up to several hundred kilometres to adjust to the increased airflow and produce the maximum effect.

□ ENJOY THE DIFFERENCE □